

Eye-Glass Interface System

Abstract:

The objective of the project is to develop a head mounted wearable display device which displays a sequence of words into the field of view of a person wearing the device in order to communicate information to the person, such as captions for hearing impaired persons or translations of speech spoken by another person. Various embodiments of the glass include an eyeglass frame, configured to be worn by the person, a housing mounted to the eyeglass frame, including a circuit for receiving a signal containing the sequence of words received by the circuit, a mirror mounted to reflect the displayed sequence of words downwardly, and a lens disposed in the path of the mirror to magnify the displayed sequence of words etc.

Team:

Akshay Bedhotiya (08026019)
Sachin A S (08D26008)
Pritish Godara (08026021)

Project Description:

The project was aimed at developing a miniature model of the visor based eyeglass interface system. We have used LCD HD44780 display system in order to display scrolling text. The text was then focused onto a beam-splitter so that the user can have a dual view of the text as well as the sight in front. In this project, we have implemented an objective quiz with answer dependent response.

Individual Work Distribution

Most of the project work was implemented by the entire team together. Akshay, Sachin and Pritish were together involved in writing the code and burning it into the circuit developed. Nevertheless the following is an objective and not so accurate take on individual work distribution

Pritish handled the hardware and material procurement. He was involved in writing the avr code as well as debugging the code. Also he was actively involved in implementing the circuit in the mechanical model developed.

Sachin was actively involved in the conceptualization of the project till the successful implementation of the same. He managed the software side of the project and worked on the avr code behind the lcd display. Furthermore, he was also involved in the troubleshooting the circuitry apart from working on the visor model developed.

Akshay managed the circuitry behind the Eyeglass interface. He played a key role in code debugging as well as troubleshooting the circuit. Moreover, he was involved in the development of the mechanical model as well.

Thank You.

CIRCUIT DIAGRAM

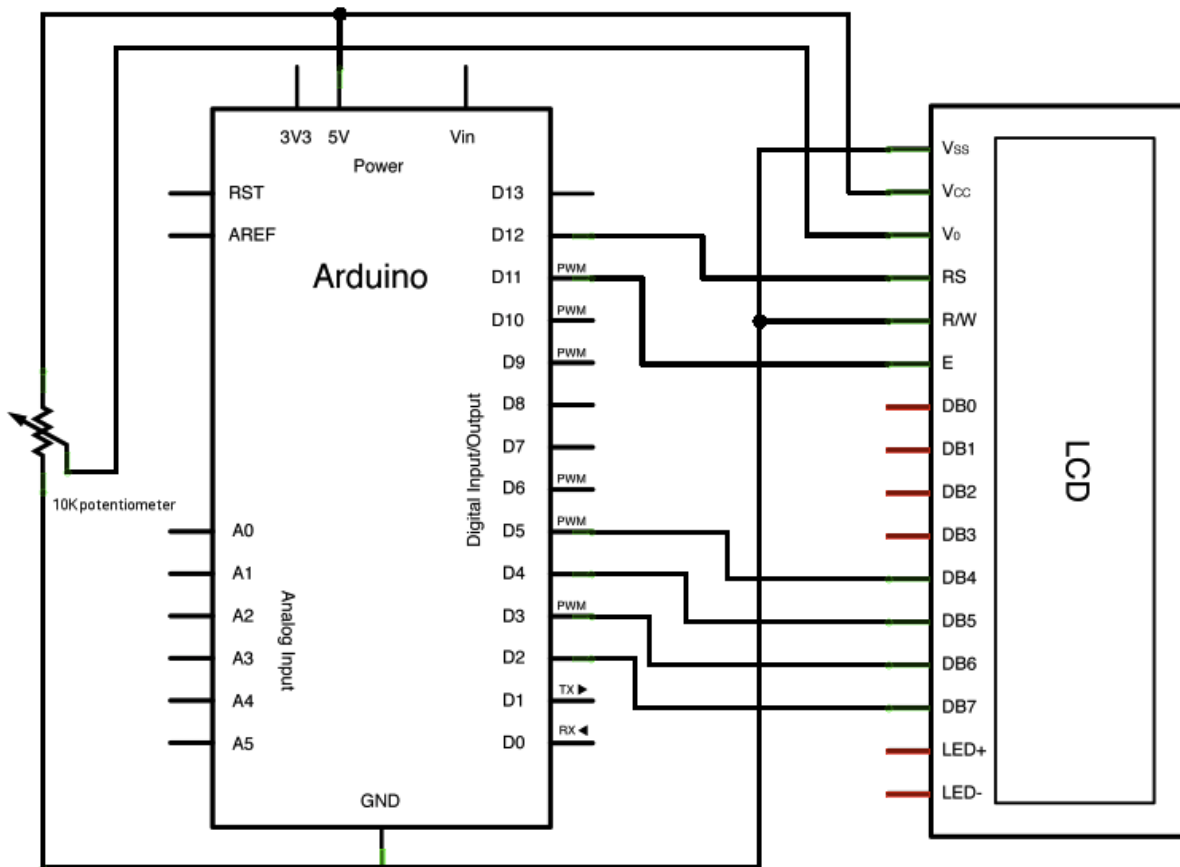

Code

```
#include <LiquidCrystal.h>

// initialize the library with the numbers of the interface pins
LiquidCrystal lcd(12, 11, 5, 4, 3, 2);

int a;

int c=0;

int d=0;

int k=0;

int lcdclear=1;

void setup(){
    // set up the LCD's number of columns and rows:
    lcd.begin(16, 2);
    // initialize the serial communications:
    Serial.begin(9600);
    lcd.print("QUIZ :");
    // delay(2000);
    // lcd.clear();
}

void loop(){
    delay(2000);
    if(lcdclear==1){
        lcd.print(" Do you want next question?");
        for (int positionCounter = 0; positionCounter < 28; positionCounter++) {
```

```
    lcd.scrollDisplayLeft();
    delay(300);
}
lcd.clear();
}
if (Serial.available()) {
    delay(100);
    a=Serial.read();
    lcd.clear();
    switch(a){
    case 'y':
        if(c==0){
            lcd.print(" what is first number?");
            for (int positionCounter = 0; positionCounter < 23; positionCounter++) {
                // scroll one position left:
                lcd.scrollDisplayLeft();
            }
            // wait a bit:
            delay(500);
        }
        lcd.clear();
        while(Serial.available()){
            a=Serial.read();
            if(a=='1'){
                lcd.print("Correct");
                delay(500);
                d++;
            }
        }
    }
}
```

```
else{
    lcd.print("wrong answer");
}
k++;
lcdclear=1;

}

}
if(c==1){
    lcd.print(" what is second number?");
    for (int positionCounter = 0; positionCounter < 24; positionCounter++) {
        lcd.scrollDisplayLeft();
        delay(300);
    }
    lcd.clear();
    if(Serial.available()){
        delay(100);
        a=Serial.read();
        if(a=='2'){
            lcd.print("Correct");
            delay(500);
            d++;
        }
        else{
            lcd.print("Wrong answer");
        }
    }
}
```

```
    k++;  
  }  
}  
lcclear=1;  
break;  
case 'n':  
  lcd.print("okay");  
  
  delay(1000);  
  lcd.print(" your score is ");  
  // delay(1000);  
  lcd.print(d);  
  for (int positionCounter = 0; positionCounter < 17; positionCounter++) {  
    lcd.scrollDisplayLeft();  
    delay(500);  
  }  
  lcd.clear();  
  break;  
}  
c=k;  
}  
}
```